

DVG

Installation and Operating Instructions for



■ English original version

DVG-H



DVG-V



DVG-H EC



DVG-V EC

Previous issues:

IMO_DVG_en_13_12_2016

Changes:

Major revision

The data stated in these operating instructions are merely for the purpose of describing the product. Information about a certain property or suitability for a certain purpose of use cannot be derived from our information. The information does not release the user from his own assessments and examinations.

Please consider the fact that our products are subject to a natural wear and ageing process.

All rights are with Systemair, also for the event of applications for protective rights.

Any powers of use, such as copying and forwarding rights, are with us.

An exemplary configuration has been shown on the title page. The product supplied can therefore deviate from the illustration. The original operating instructions have been written in English language.

Contents

1	General information	4	8.2	Safety elements.....	11
1.1	List of information	4	8.3	Commissioning.....	11
1.1.1	Specific safety symbols	4	9	Operation	12
1.1.2	List of instructions for action	5	9.1	Safety notes	12
1.2	Notes on the documentation.....	5	9.2	Operating conditions.....	12
2	Important safety information	5	9.3	Operation/use	13
2.1	Safety notes	5	10	Maintenance/troubleshooting	13
2.2	Personnel	5	10.1	Malfunctions and troubleshooting (generally)	14
2.2.1	Mounting personnel	5	10.2	Cleaning.....	14
2.2.2	Work on the electrical equipment.....	5	10.3	Maintenance, service	14
2.2.3	Personnel for operation/use, maintenance and cleaning.....	6	10.4	Spare parts	15
2.3	Intended use	6	11	Uninstalling/dismounting	16
2.4	Improper use	6	12	Disposal	16
3	Warranty	6	12.1	Disposal of the fan	16
4	Transport, storage	7	12.2	Disposal of packaging.....	16
4.1	Transport	7		Appendix 1: Mounting of service switch/ mounting of vertical outlets at DVG-V.....	17
4.2	Storage.....	7		Appendix 2: Wiring diagrams	18
5	Description	8		<i>Appendix 3: Wiring diagrams DVG-EC 1~</i>	20
5.1	Technical data	8		<i>Appendix 4: Wiring diagrams DVG-EC 3~</i>	22
5.2	Dimensions	8		Appendix 5: Accessories DVG-H - mounting	24
6	Installation	8		Appendix 6: Accessories DVG-H - mounting	25
6.1	Safety information	8		<i>Appendix 7: Sealing of cable glands (DVG-EC only)</i>	26
6.2	Preconditions for installation.....	9		EC-Declaration of Conformity	27
6.3	Installation	9			
7	Electrical connection	10			
7.1	Residual current circuit breaker	10			
7.2	Connection of thermal protection (<i>not applicable at DVG-EC</i>).....	11			
8	Commissioning	11			
8.1	Preconditions	11			

1 General information

1.1 List of information



DANGER

Direct danger

Failure to comply with this warning leads directly to death or to serious bodily harm.



WARNING

Possible danger

Failure to comply with this warning potentially leads to death or to serious bodily harm.



CAUTION

Hazard with a low risk

Failure to comply with this warning potentially leads to moderate injuries.

ATTENTION

Hazard with risk of property damage

Failure to comply with this warning leads to property damage.



NOTE

Useful information and notes

1.1.1 Specific safety symbols



DANGER

Hazard of injury from rotating parts, if not covered with protective grid!

This warning identifies situations with a danger for life from touching impeller. Failure to comply with this warning leads to the risk of death or serious injuries.



WARNING

Hazard from electrical current!

This warning identifies situations with a danger for life from electrical current. Failure to comply with this warning leads to the risk of death or serious injuries.



WARNING

Hazard from bursting parts!

This warning identifies situations with a danger from bursting parts. Failure to comply with this warning potentially leads to the risk of serious injuries.





WARNING

Hazard from hot surface!



This warning identifies situations with a danger from overheating. Failure to comply with this warning potentially leads to property damage.

1.1.2 List of instructions for action

Instruction for action

-  Carry out this action.
-  (if applicable, further action)

Instruction for action with fixed order

-  Carry out this action.
-  Carry out this action.
-  (if applicable, further action)

1.2 Notes on the documentation



WARNING

Hazard as a result of improper dealing with the fan

These operating instructions describe safe use of the device.

- Read the operating instructions carefully! The personnel dealing with the fan must read and understand the operating instructions.
- Keep the operating instructions with the device. They must be permanently available at the place of use.

2 Important safety information

2.1 Safety notes

Designers, installers and operators are responsible for the **proper mounting and intended use**.

- Only use the fan in a proper condition.
- Provide generally prescribed electrical and mechanical protective devices.
- During mounting, commissioning, maintenance and control, secure the place of mounting against unauthorised access.
- Observe rules for safe work. Protective working gloves, protective working shoes, safety goggles, safety helmet are part of personal protective equipment. Depending on object, additional protective equipment may be necessary.
- Safety components must not be by-passed or put out of function.
- Keep all the warning signs and nameplates on the fan complete and readable.
- Regularly instruct the personnel about safety-conscious behaviour. Requirements for personnel – see 2.2. The appliance is not to be used by persons (including children) with reduced physical, sensory or mental capabilities.



NOTE

We have carried out a risk assessment for the fans. However, it can only apply to the fan itself. After installation of the fan, we recommend to carry out a risk assessment for the whole system. In this way, you have the guarantee that there is no risk potential from the system. Compliance with EMC Directive 2014/30/EC only relates to these products when they have been connected directly to the customary power supply.

2.2 Personnel

2.2.1 Mounting personnel

- Mounting may only be carried out by trained, qualified personnel.

2.2.2 Work on the electrical equipment

- Work on the electrical equipment of the fan may only be done by a qualified electrician or electro technically educated person. This person must know the relevant safety rules to recognise and avoid potentially risks.

2.2.3 Personnel for operation/use, maintenance and cleaning

- Operation/use, maintenance and cleaning may only be carried out by trained and authorized personnel. The operating personnel must have appropriate knowledge about handling with the fan. In the case of a malfunction or an emergency, they must react correctly and adequately.

2.3 Intended use

DVG fans are intended for installation in ventilation systems, outside buildings only (on roofs). They can be installed either in duct systems or as a free sucking fan over a nozzle and a sucking side protection grid.

- DVG fans are suitable for extraction of clean air, air with a low dust and grease content, media up to max. density of 1,3 kg/m³ and permissible moisture of max. 95 %. **When applied for kitchen exhaust, regularly cleaning of impeller and housing is necessary.**
- The maximum permissible operating data on the name plate apply for an air density $\rho = 1,2 \text{ kg/m}^3$ (sea level) and a maximum air moisture of 80 %.
- The fans are generally suitable for ambient temperature -20 to +40°C (depending on specific motor load the permissible ambient temperature may be increased - on request).
- Daily ventilation of medium -20 up to 120°C, continuous operation (*DVG-EC/F400 up to 80°C in standstill*). On request motors can be equipped with electric heaters to meet lower temperatures.
- **Smoke and heat extract roof fans DVG/F400** are intended to exhaust hot gases up to 400°C/120 min (F400/120, F400/90, F300, F200). They are designed for use in powered smoke and heat exhaust ventilating systems in the event of fire, and ventilating in normal conditions (dual use). Ventilated areas and emergency exits contribute to easier evacuation of people and equipment in the event of fire, and to faster and more efficient fire extinguishing; they protect the building structure and equipment against excessive temperatures and decrease fire escalation to the surrounding areas. Snow load classification: SL 1000 for DVG-H/F400 with horizontal outlet – suitable for installation over heated or unheated buildings up to SL 1000 (provide appropriate height of the roof base). DVG-V/F400 with vertical outlet with classification SL 0 are suitable for installation only on the top of heated buildings, considering possible heat transfer. In case of fire all motor protective devices and controls must be bridged to guarantee functional capability (connection direct to mains).
- **Versions DVG-T and DVG/120 can be used for common daily ventilation only, not to be used for smoke extraction.**

2.4 Improper use

Above all, the improper use means using the fan in a way other than that described. The following points are improper and hazardous:

- Use of a fan with improper identification (temperature/time class in case of smoke extraction);
- Not suitable to exhaust dust containing medium or medium with such dust concentration, that could affect with dust deposits on operation and explosion protection (appropriate filtering necessary);
- Extraction of grease containing media (or regularly cleaning must be assured);
- The fans DVG are not intended to exhaust from explosion hazardous zones;
- In case of suction aggressive atmosphere additional acid protection of exposed parts is necessary;
- Not suitable for indoor use;
- Operation without duct system or protective guard (intake protection);
- Operation with the air connections closed;
- Operation without effective thermal protection (PTC).

3 Warranty

Warranty for our products shall be determined according to the contractual agreements, our quotations and, as a supplement, our General terms and Conditions of Business. Warranty claims shall presuppose that the products are correctly connected, operated and used accordingly to data sheets, and regularly maintained.

4 Transport, storage

4.1 Transport

Each fan leaves our plant in an electrically and mechanically proper condition. The fans are delivered in wooden crates or cardboard boxes. We recommend transporting the fans to the installation site in original packaging.



WARNING

Hazard of impact if the fan falls down!

- Load and unload the fan carefully in order to avoid possible damage.
- Pay attention to the weight and dimensions of the packaging. The weight of the fan is visible from the nameplate.



CAUTION

Danger from cutting edges!

- Wear protective working gloves when unpacking.

 Check the fan for obvious defects, which can impair safe operation.

 First of all, pay attention for defects on the connection cable, service switch and impeller, cracks in the housing, missing rivets, screws or covering caps.



WARNING

Electrical hazard from damaged connection cable or connections

- Do not use the connection cable, service switch or impeller for transport or hoisting.





WARNING

Hazard of impact if the device falls down!

- Transport the device carefully and with appropriate hoisting device!
- Wear a safety helmet and safety goggles!

 Only put the fan at unpacking on its base plate.

 At manual transport observe allowed human lifting respectively carrying forces (see weight on the name plate).

 Avoid impacts and distortion of the base plate and other parts of housing.

4.2 Storage



CAUTION

Hazard due to loss of function of the motor bearings!

- Avoid storing for too long time (recommendation: max. 1 year).
- Turn the impeller manually every three months, wear protective working gloves.
- Before installation, check proper function of the motor bearings

 Store the fan in the original packaging dustproof, dry and protected against weather.

 Avoid effects of extreme heat or cold.

5 Description

The casing is manufactured from seawater resistant aluminium. The base plate with nozzle consists of pre-galvanized steel. Impellers with backward-curved blades are welded and galvanized (sizes 355 and 450 have impellers made of pre-galvanized steel and tabbed). They are fastened together with hub and secured screw directly on to the motor shaft. Dynamically balanced to ISO 1940 T1, class G6,3.

Serially equipped with B5 electric motor 3x400V~, 50Hz, IP 55, insulation class F, with built-in PTC. On request, the fan can be equipped with electric motor intended for other voltage/frequency. Electric motor outside air stream is cooled with fresh air. All sizes are serially equipped with service switch.

Electric motor	Connection	Efficiency class, serially:
Single speed (4 pole, 6 pole, 8 pole)	Y or D	IE2 or IE3 (IE1 exceptions: up to 0,55 kW and 8 pole)
Two speed (4-6, 6-8)	Y/Y	IE1
Two speed (4-8, 6-12) Dahlander	YY/Y	IE1

DVG-EC only: Serially equipped with EC (electronically commutated) high efficiency electric motors for single-phase supply 200 to 265V, 50/60Hz Hz (sizes 355 and 450), respectively 342 to 506V, 50/60Hz Hz (sizes 560, 630, 800). Protection class IP 54. Insulation class F. Max. RPM: 1500 RPM, respectively 900 RPM at DVG 800. Prewired with controller and the connection box outside on the casing.

5.1 Technical data

Size	Max. synchronous RPM at 50 or 60 Hz for DVG/F400**	Max. nominal power at 50 Hz*/**	Impeller diameter	Max. weight** DVG/F400	Max. sound power level inlet**	Max. sound power level outlet**
	min-1	kW	mm	kg	dB(A)	dB(A)
315	1500	0,37	325	41	78	77
355	1500	0,37	365	43	81	78
400	1500	0,55	410	47	85	86
450	1500	1,1	454	58	88	88
500	1500	1,5	520	91	90	93
560	1500	2,5	570	107	94	94
630	1500	4,6	650	144	96	101
800	1000	5,5	820	223	96	99

*Motor data (input power P1, current, RPM) and data of the fan are visible on the nameplate and on the test protocol.
 **DVG-T, DVG/120 and DVG-EC may vary from these data due to special motors

5.2 Dimensions

Please see www.systemair.com.

6 Installation

6.1 Safety information



WARNING

Hazard from falling parts!

- Check the base/roof before installation for load capacity/strength.
- When selecting the hoisting device and fitting material observe the weight, tendency to vibrations and shear forces (weight information on the nameplate).

CAUTION
Danger from cutting edges!

- At installation works wear protective working gloves.

6.2 Preconditions for installation

- DVG fans must be installed on roofs, outside fire zone (DVG/F for exhausting from fire zone).
- The fans must be mounted on a flat, horizontal roof base (<10 mm/m) with height of min. 250 mm over the rooftop (motor shaft vertical). The base shall be accordingly designed (load capacity, stiffness, insulation), if not proved Systemair accessories used. Extremely wind or turbulence exposed places should be avoided in order to prevent any water droplets ingress under extreme weather conditions. **Use DVG-V outlets to reduce this danger.**
- During installation the site must be protected from dust, moisture and weather influences.

6.3 Installation

- Ensure secure access to the fan for maintenance and service.
- Mounting of service switch and vertical outlets (DVG-V) up to Appendix 1. Installation examples up to Appendix 5/6.
- Fit the contact surface between base plate and roof base with temperature resistant sealing tape for DVG/F or foam sealing tape for DVG/120, DVG-T. Systemair roof bases (for smoke extract fans marked with /F) are delivered with appropriate sealing tape.

WARNING
Hazard from mechanical distortions!

- Before and after mounting check manually if the impeller rotates smoothly. Install the fan only, if the minimum air gap between rotor and nozzle matches the value from the test protocol.
- Avoid distortions of the casing at installation.

- The fans shall be fixed to the base with 4 screws in the corners.
- Ensure unobstructed and uniform intake into the fan as well as free outlet.
- Install connecting ducts and accessories. The suction side of the fan is provided with a connection for flange-type mounting of the air duct (according EUROVENT at sizes 560 to 800), dimensions see www.systemair.com.
- Provide for contact/suction protection and safety distances according to EN ISO 13857.

NOTE

In some cases, it is better to mount accessories before placing the fan on the roof base.

NOTE

It is recommended to install a flexible connection between the fan and duct to avoid eventual tensions or distortions of the base plate (for F400 only: appropriate flexible connection should take eventual thermal extension of connecting parts. Flexible connection has to comply temperature/time class of the fan (400°C/2h); also as certified Systemair accessory available).

NOTE

It is recommended to keep sufficient ventilation rate to avoid condensation in cold corners of the roof base under certain weather conditions or to insulate any heat bridge in case of low ventilated buildings.

NOTE

Data of accessories are on-line available - www.systemair.com.

7 Electrical connection

The wiring diagram is placed inside the cover of service switch (also in the test protocol). *At DVG-EC the wiring diagram is placed in the connection box.* The quality and installation of cables for electrical connection must ensure uninterrupted energy supply, even in case of fire. Inside fire zone use only certified cable. The electric cable must not be in contact with or be fastened to the casing of the fan (F400 only, high temperature!). Connecting possibility see Appendix 2. Electrical data on the fan nameplate must comply with the provided mains connection. Equivalent motors from different suppliers may have slightly different nominal data than in catalogue.



NOTE (NOT APPLICABLE AT DVG-EC)

- Motors have serial built-in PTC. More than two PTC chains may not be switched in series, as this can lead to undefined cut-outs.
- Maximum check voltage of PTC is 2,5 V.
- The wiring diagrams see Appendix 2.
- Motor protection must be provided by the installer.



NOTE (DVG-EC ONLY)

- *The controller has built-in thermal protection.*
- **Observe attached detailed instructions of motor and controller supplier (1~ unit instruction for controller "Compacto", 3~ unit instruction for controller "Invento").**
- *Power supply connection in the service switch, control cable in the connection box. Wiring diagrams and descriptions in Appendix 3 (DVG-EC 1~) and Appendix 4 (DVG-EC 3~).*
- *Since EC motor built-in, there are warnings for remaining voltage after supply switched off.*
- *Type of permitted RCD protective devices observe local regulations.*



WARNING

Hazard from electrical voltage!

- Electrical connection only by a trained electrician respectively trained and instructed qualified personnel!
- Electrical connection in accordance with the valid regulations.
- Prevent the ingress of water into the connection box.
- Observe 5 safety rules for the electrical expert!
 - disconnect from the power supply (all-pole),
 - prevent switching on again,
 - test absence of voltage,
 - earthing and short-circuiting,
 - protect adjacent live parts by covers and barriers and fit a suitable warning notice.



Connect the cable according to wiring diagram.



Tighten the nuts of cable glands well to achieve IP68 protection.



Check, if the cover of service switch is uniformly fastened. If there is a danger of unintended switch off of the service switch, it should be locked to guarantee operation in fire case (F400). Drill a hole into the handle in the "on" position and provide with a padlock (not supplied with the fan). See Appendix 1.



Place the supply cable.

7.1 Residual current circuit breaker



Use universal RCDs type B or B+ in case of speed control with frequency converter.

7.2 Connection of thermal protection (*not applicable at DVG-EC*)



CAUTION

Property damage as a result of motor overheating

- The motor can overheat and be destroyed if the PTC not been connected.
- PTC always connect to a motor protective device!

8 Commissioning

8.1 Preconditions

- Mounting and electrical connection have been correctly performed.
- Installation residuals and foreign objects have been removed from the fan and ducts.
- Inlet and outlet are free.
- The safety devices have been fitted (protection against contact with rotating impeller).
- The protective conductor and external earth conductor have been connected.
- The thermal protection is properly connected to the motor protective device:
 - the motor protective device is functional;
 - the thermal protection is functional.
- The cable glands are tight.
- Provided mains connection complies with the data on the nameplate.
- The current (from the nameplate) does not exceed the mains data.

8.2 Safety elements



DANGER

Hazard from injurie from rotating parts, if not covered with protective grid!

The outlet protective grid is serially provided.

-  Check if the safety elements e.g. protective grids are fastened.

8.3 Commissioning



WARNING

Hazard from electrical voltage!

- Commissioning by trained and instructed qualified personnel only!

-  Switch the ventilator on as planned.



WARNING

Hazard from bursting parts!

- When checking the direction of rotation, wear safety goggles.

-  Check:

- the direction of rotation (all speed!). Switch the fan for a short period on and then off to check the direction of rotation of impeller. **The rotation must comply with the arrow on the casing.** If wrong, swap two phases.
- leave the fan running, check, if running smoothly (eventual vibrations and noise);
- measure current with appropriate instrument (it may exceed nominal current by a max. 5%);
- tightness of all joints.

-  Fill in the attached test protocol of the fan and submit it in case of warranty claim.

9 Operation

9.1 Safety notes



WARNING

Hazard from electrical voltage!

- The device may only be operated by persons
 - instructed in function and risks,
 - who have understood handling and can accordingly react.
- Ensure access only to persons, who can safe handle the device.

9.2 Operating conditions

- During operation, touching the impeller must not be possible.
- Safety components must not be bypassed or put out of function.
- Prevent sucking of foreign particles, this can destroy the fan.
- Switching frequency:
 - the fan is intended for S1 continuous operation!
 - the control equipment must not allow any extreme switching!
- **The fan may operate only within the limits declared on the nameplate.** Operation above 50 Hz is allowed for the fans accordingly designed and marked on the nameplate. The DVG/F400 fan can be approved for 60 Hz operation, if synchronous speed at 60 Hz does not exceed the data from the table in section 5.1.
- **If the fan is used for smoke and heat extract (F400) in case of fire bridging of motor protective devices is necessary to assure operation. Switch on max. speed even after eventual short supply cut off must be assured.**
- The fans were hot tested with frequency converter and sine filter. However, it is recommended to bridge eventual converter in case of fire (to prevent any error at motor protection setting or operation). **If frequency converter is used in case of fire, PTC and any motor protection must be bridged and switch on max. speed even after eventual short supply cut off assured.**
- In case of speed control via frequency converter - **min. 20 Hz ÷ max. 50 Hz (rsp. 60 Hz, if declared for 60 Hz)**, make sure that the voltage peaks on the connection terminals of the fan are lower than 1000 V and voltage rise velocity is lower than 500 V/μs (IEC 34-17).

ATTENTION

Hazard with risk of additional costs

- For speed control is recommended a combination of frequency converter and appropriate all-pole sinus filter (or minimum dU/dt filter). It is particularly important, if the supply cable is long, but also to reduce the motor noise. It may only be abandoned, if proven, that the voltage peaks on the connection terminals of the fan are lower than 1000 V and the voltage rise velocity is lower than 500 V/μs.
- At frequency controlled units additional EMC protection of cable and service switch could be needed (on request).
- Subsequently fitting of EMC shielded cable from motor to connection box/service switch is connected with disassembly of the fan!
- **The motors cannot be voltage controlled!**
- Exceptions, suitable for voltage control: DVG-H/V 400D4V/F400
- In the DVG fans there are not any two speed motors in Y230V/D400V connection built-in; two speed motors are only in Y400V/Y400V or Y400V/YY400V connection.
- Small single speed motors (Y400V) are in motor connection box connected in Y; it is impossible to change the connection to D230V without disassembly of the fan (for eventual 3x230V frequency converter).





NOTE

At single speed motors with nominal power from incl. 5,5 kW (D400V) we recommend “star – delta” starting. For this purpose all 7 wires are led to connection box/service switch.

NOTE (DVG-EC ONLY)

- 0-10V speed control input.
- Modbus controllable.
- **Fire mode to disable motor protection and controller protection in case of fire.**

9.3 Operation/use

-  Only use the fan in accordance with this operating instruction and the operating instructions of motor.
-  Control the fan during operation for correct function.
-  Switch the fan off as planned.

WARNING

**Hazard from electrical voltage and flying parts!
Errors occurring can lead to personal and/or property damage!**

Switch the fan immediately off as planned:

- In cases of a non-typical noise from bearings, vibrations, pressure pulsation.
- In case of overcurrent, overvoltage or temperature (nameplate). Then try to find the reason - see chapter 10.

10 Maintenance/troubleshooting

WARNING

Hazard from electrical voltage!

- Trouble setting and service only by a trained electrician or trained and instructed qualified personnel!
- Observe rules for safe work at maintenance/troubleshooting, cleaning and service!
- Observe 5 safety rules for the electrical expert!
 - disconnect from the power supply (all-pole),
 - prevent switching on again,
 - test absence of voltage,
 - earthing and short-circuiting,
 - protect adjacent live parts by covers and barriers and fit a suitable warning notice.

DANGER

Hazard from injurie from rotating parts, if not covered with protective grid!

The outlet protective grid is serially provided. If needed to remove protective grids temporarily, assure:

- Electrical circuit must be interrupted and secured against restarting.
- Impeller must stand still.
- Immediately after finished work fix protective grids.

CAUTION
Danger from hot surfaces!

- During maintenance/troubleshooting and cleaning wear protective working gloves to prevent contact with hot motor!

10.1 Malfunctions and troubleshooting (generally)

	Possible reasons	Action
The ventilator does not run	Connection to the mains fault. Thermal protection triggers. Motor fault.	Check connection to the mains and thermal protection. If ok, check electric motor (winding resistance, resistance to ground). If two speed motor (4-6, 6-8, 4-8, 6-12) is installed, check all speed. If necessary, get the electric motor repaired.
Air volume is too low	Wrong direction of rotation. Too high pressure drop in system. Obstacles in duct.	Check the direction of rotation. If wrong, swap the supply connection of any 2 phases. Check if current is similar all phases. If ok, check operating point and system design.
Thermal protection of the fan switches off	Short-circuit. Damage to the bearings. Impeller blocked or grinding.	Compare connection with wiring diagram. Compare the data of electric motor with setting of thermal protection. If ok, check power supply and electric motor. Get the electric motor or if necessary the complete fan repaired.
	Overcurrent	Check the direction of rotation. If wrong, swap any 2 phases. Check if current is similar all phases.
Noise	Damage to the bearings. Impeller blocked or grinding.	Get the electric motor or if necessary the complete fan repaired.
	Loose fit on the base plate or motor support.	Tighten the bolts, look for the cause of vibrations.
Vibrations	The actual pressure drop of the system is higher than supposed, the fan could operate in an unstable area of the fan curve.	Check operating point and system design. Consult customer service of the manufacturer.
	Damage or dust layer on impeller.	Clean the impeller, if necessary balance it or replace it.

If the reason for malfunction cannot be clearly determined, consult the customer service of manufacturer.

10.2 Cleaning

Regular cleaning prevents unbalance.

- ☞ Keep casing and impeller clean and clean them if necessary with a brush (do not use a steel brush or high-pressure cleaner). Do not use any detergents for interior cleaning. Regular cleaning is particularly important, if there are trees in the neighbourhood. The gap between casing and base plate must be kept free for water drain and may not be covered by needles or leaves.

10.3 Maintenance, service

Basically the fan may be repaired at the manufacturer only! Exceptions are non-relevant components. For further instructions consult the manufacturer.

The fan is by built-in for-life lubricated ball bearings as far as possible low-maintenance product. After their life time (app. 30.000 – 40.000 h), a replacement of the bearings is necessary. Observe attached instructions of motor manufacturer.

- ☞ Pay attention to a non-typical noise from bearings.
- ☞ For damages (e.g. damage to winding) please contact our Service Department. You will find the address on the back of these operating instructions.

Maintenance and check points of fans similarly to VDMA 24186-1 (type, scope and maintenance intervals to be specified in dependence of use and operating conditions).

VDMA 24186-1	Description	Maintenance interval		
		Monthly	Every 3 months	Once a year
	Fan and electric motor of the fan			
1.1.11	Check the drainage for function			x
6.1.1	Check to dirt, damage, corrosion and fastening		x	
6.1.2	Functional cleaning			x
10.1.6	Check the terminals for tightness			x
10.1.9	Test the fan for function und operational readiness (test run app. 15 min.)		x	
6.1.4	Check the bearings for noise			x
10.1.3	Check impeller for direction of rotation (all speed)			x
6.1.3	Check impeller if damaged or unbalanced (if necessary provide vibration measurement)			x
10.1	Functional test of automatically bridging of all thermal and overcurrent protective devices		x	
10.1.7	Measure the current			x
10.1.12	Test function of protective device		x	
	Triggering device			
	Check it for function	x		
	Test of functions			
	Test all functions of system from control panel as well as signal lights	x		
	Check the safety measures (protective elements, signs, guards)		x	
	Accessories (air ducts, air louvers, flaps, sound attenuators)			
5.5.1	Check accessible ducts inclusive fire protective insulation and fastening for outside damages and corrosion (visually)			x
5.5.4	Check accessible flexible connections for tightness (visually)			x
5.2.1 5.2.3	Flaps and sound attenuators check for dirt, damage and corrosion Check mechanical functionality of the flaps			x
5.1.1	Check air louvres for dirt and damage (visually)			x

10.4 Spare parts

In case of order of spare parts please specify the serial number of the fan. You can find it on the nameplate or in the test protocol.

Spare parts: electric motor (there is a restriction to use only from the test lab allowed motors), impeller, service switch, casing.

How to replace electric motor, impeller or actuator - please contact manufacturer for instructions.

11 Uninstalling/dismounting



WARNING

Hazard from electrical voltage!

- Disconnection and uninstalling only by a trained electrician or trained and instructed qualified personnel!
- Observe 5 safety rules for the electrical expert!
 - disconnect from the power supply (all-pole),
 - prevent switching on again,
 - test absence of voltage,
 - earthing and short-circuiting,
 - protect adjacent live parts by covers and barriers and fit a suitable warning notice.



CAUTION

Danger from cutting edges and impact!



- Wear protective working gloves when dismantling!
- Dismount carefully.



WARNING

Hazard from falling parts!



- When selecting the hoisting device observe the weight (weight information on the nameplate).

-  Carefully disconnect all wires.
-  Remove the fan from duct. Carefully remove the fastening material.
-  Lift the fan with an appropriate hoisting device on the provided lifting eyes. Place the fan on appropriate pallet.

12 Disposal

12.1 Disposal of the fan

Should the fan be disposed, proceed as follows:

-  Disassemble the fan into its components.
-  Separate the parts according to
 - reusable material
 - material groups to be disposed (metal, plastics, electrical parts, etc.)
-  Provide for the recycling of material. Consider the national regulation.

12.2 Disposal of packaging

-  Provide for the recycling of material. Consider the national regulation.

**Appendix 1: Mounting of service switch /
Mounting of vertical outlets at DVG-V**

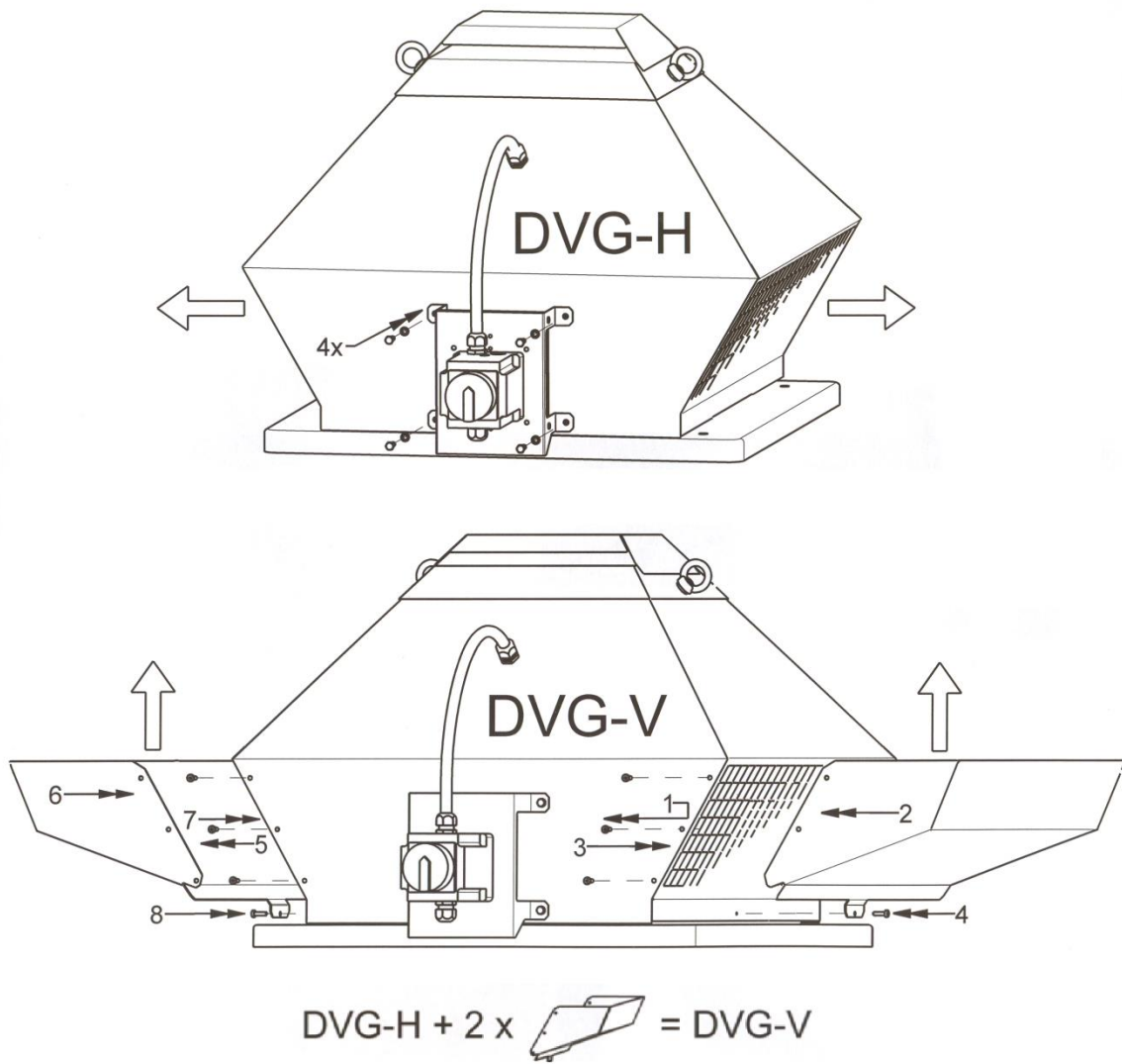

Properly mounted service switch,
cable protected inside tube

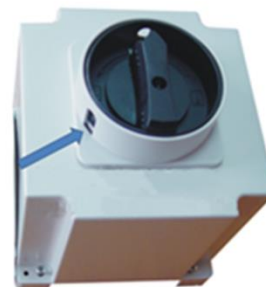

See IMO, Section 7

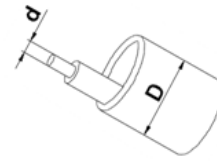
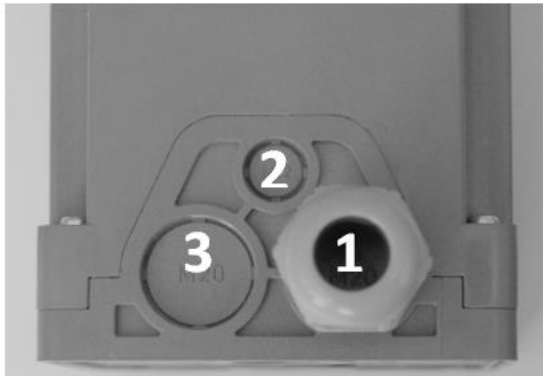

1	M20x1,5	Power supply + PTC	d max. 4	D max 14,5 mm
2	M12x1,5	-		
3	M20x1,5	-		

Single speed motor up to inclusive 4 kW output power,
4 pole, 6 pole, 8 pole

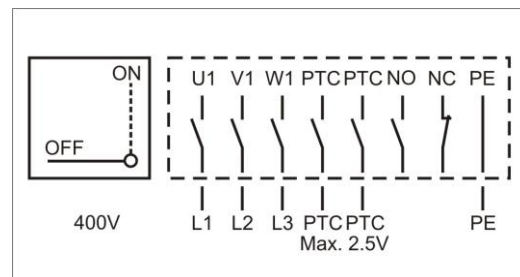

Single speed motor,
DVG-H/V 400D4V/F400 – it can be voltage controlled

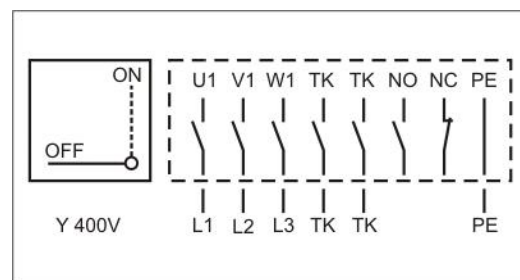

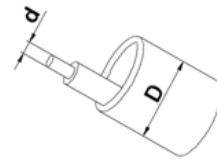
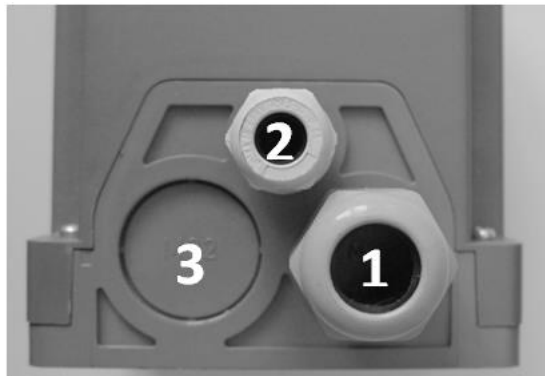

1	M25x1,5	Power supply	d max. 4 mmq	D max 16,5 mm
2	M16x1,5	PTC	d max. 1,5 mmq	D max 10 mm
3	M32x1,5	-		

2 speed motor in Dahlander connection,
4-8 pole

Y400V...low speed, YY400V...high speed

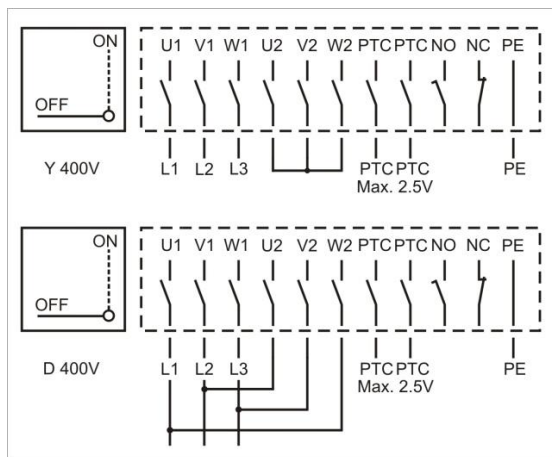
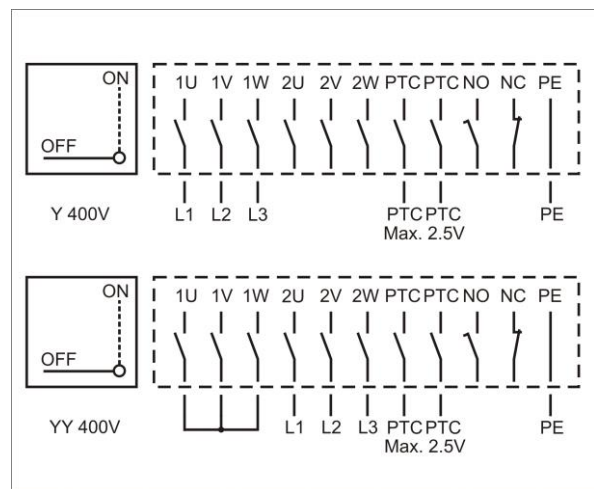

Single speed motor with star – delta starting
(motors with output power more than 4 kW)

Starting in Y, operation in D

Warning: it is not 2 speed motor!

2 speed motor with separated windings,
4-6, 6-8 pole

1U, 1V, 1W...low speed

2U, 2V, 2W...high speed

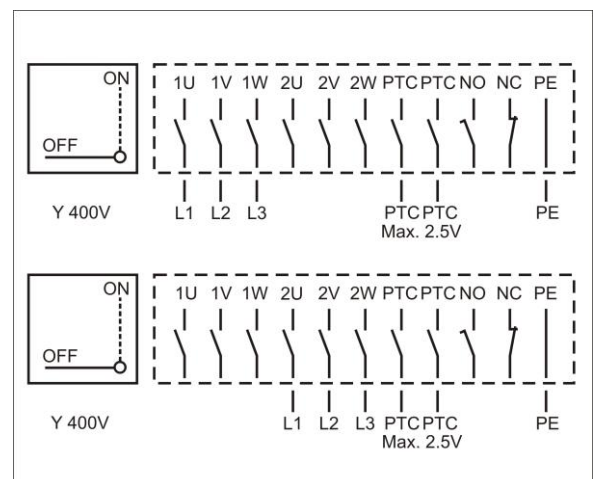

Appendix 3: Wiring diagrams DVG-EC 1~

Symbol	Description
G1	Fan DVG-EC
G2	EC controller - terminals prewired with connection box on the casing
G3	Service switch ON-OFF, 6 pole + 1xNC
F1	Fault relay
F2	Analog input for set value / speed setting
F3	Potentiometer for speed setting
F4	External sensor
F5	Speed output
F6	FIRE mode (open = FIRE)
F7	Start/Stop switch (open = stop)
F8	Modbus
E1	Power supply - connection in G3 Max. cable cross-section: 2,5 mm ² (4 mm ² without core end sleeves) Max. cable diameter: 13 mm Cable gland on supply side included: 1xM20x1,5 Possible to install additional cable glands 1xM20x1,5, 1xM16x1,5
E2	Control cables - connection in G2/connection box on the casing Max. cable cross-section: 1,5 mm ² , recommended 0,75 mm ² , max. cable diameter: 13 mm Cable glands on the connection box: 2xM20x1,5 for control cables 2 cable inserts with 3x5 mm hole enclosed for thinner control cables alternatively Eventual protecting tube for control cables not enclosed
E3	EC-Motor pre-wired

	Marking	Terminal No.	Description
Mains supply	PE	1	PE connection
	N	2	Neutral
	L	3	Supply voltage 1~ 200-265V/50-60Hz
Fault relay	NC	4	Normally close
	COM	5	Common connection; contact rating 250V/5A
	NO	6	Normally open
User interface	An1	7	Analog input 1; set value 0-10V; R >= 1k Ω
	GND	8, 12, 14	I/O ground
	Pot	9	Potentiometer output (3 wires)
	+5V	10	+5V +/-5% / 10mA for potentiometer
	An2	11	Analog input 2 for external sensor
	+24V	13, 16, 19	+24V +/- 5% DC (unregulated) voltage / I _{max} 40 mA
	Speed	15	Digital output; speed output PWM signal f ~ 1,1 kHz; NPN open collector output
	Fire	17	Digital input; FIRE mode enabling function - open pin disabling function - bridge to +24V
	Start/Stop	18	Digital input; start/stop start - bridge to +24V stop - open pin
	A	20, 22	Bus connection RS485 - A; MODBUS RTU
B	21, 23	Bus connection RS485 - B; MODBUS RTU	
Motor connection	PE, U, V, W	24, 25, 26, 27	Motor pre-wired

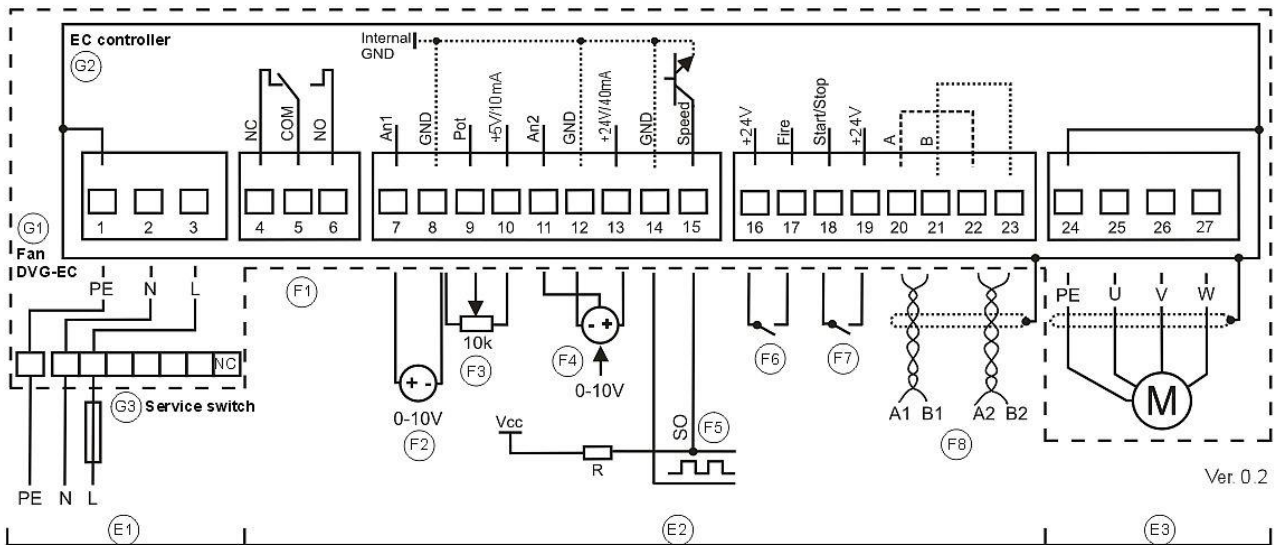

DVG 355-EC, DVG 450-EC – Wiring 1~, 230V, 50/60Hz.....27.11.2013

Terminals 4 to 23 (lower markings in the connection box) are led from controller out to outer connection box.

3 bridges are factory inserted to allow test of fan without connecting control cables.

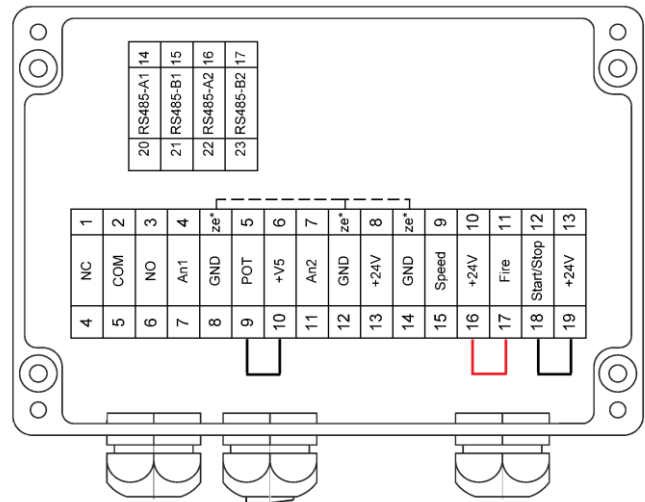

In case of using the fan for smoke and heat extraction, remove the red bridge 16-17 (fire mode) and connect controller to fire central up to wiring scheme. **Warning:** removing this bridge without connecting to fire central and running the fan in fire mode causes no protection is active. Running in fire mode is allowed only in case of fire or during periodical tests.

For fan speed setting with potentiometer remove bridge 9-10 and connect potentiometer ($R \geq 1k\Omega$) according to wiring scheme.

For fan speed setting using AN1 input (0-10V): remove bridge 9-10 and connect 0-10V input according to wiring scheme.

Replace bridge 18-19 with start – stop switch.

Controller default setup controls the fan speed with potentiometer or AN1 input.

Using internal regulator for fan speed control requires change of controller setting via MODBUS (see controller instructions). Using MODBUS for fan speed control requires change of controller setting via MODBUS (see controller instructions).

Minimum fan speed can be increased in setup via MODBUS. Maximum fan speed can be decreased in setup via MODBUS.

More about settings please see controller instructions.

Symbol	Description
G1	Fan DVG-EC
G2	EC controller - terminals prewired with connection box on the casing
G3	Service switch ON-OFF, 6 pole + 1xNC
F1	Fault relay
F2	Speed output
F3	Potentiometer for speed setting
F4	Analog input for set value/speed setting
F5	External sensor
F6	FIRE mode (open = FIRE)
F7	Start /Stop switch (open = stop)
F8	Modbus
E1	Power supply - connection in G3 Max. cable cross-section: 2,5 mm ² (4 mm ² without core end sleeves) Max. cable diameter: 13 mm Cable gland on supply side included: 1xM20x1,5 Possible to install additional cable glands 1xM20x1,5, 1xM16x1,5
E2	Control cables - connection in G2/connection box on the casing Max. cable cross-section: 1,5 mm ² ; recommended 0,75 mm ² , max. cable diameter: 13 mm Cable glands on the connection box: 2xM20x1,5 for control cables 2 cable inserts with 3x5 mm hole enclosed for thinner control cables alternatively Eventual protecting tube for control cables not enclosed
E3	EC-Motor pre-wired

	Marking	Terminal No.	Description
Fault relay	NC	1	Normally close
	COM	2	Common connection; contact rating 250V/3A
	NO	3	Normally open
User interface	Speed	4	Digital output; speed output PWM signal; $f \sim 1,1 \text{ kHz}$; NPN open collector output
	GND	5, 9, 13	I/O ground
	An1	6	Analog input 1; set value 0-10V; $R \geq 1\text{k}\Omega$
	+10V	7	+10V +/-5% / 15mA
	An2	8	Analog input 2 for external sensor
	Fire	10	Digital input; FIRE mode enabling function - open pin disabling function - bridge to +24V
	+24V	11	+24V +/- 5% DC / $I_{\text{max}} 50 \text{ mA}$
	Start/Stop	12	Digital input; start/stop start - bridge to +24V stop - open pin
	A	14, 16	Bus connection RS485 - A; MODBUS RTU
	B	15, 17	Bus connection RS485 - B; MODBUS RTU
Motor connection	M1-M6	M1-M6	Motor pre-wired
Mains supply	PE	PE	PE connection
	L1, L2, L3	L1, L2, L3	Supply voltage 3~ nominal 380-460V/50-60Hz

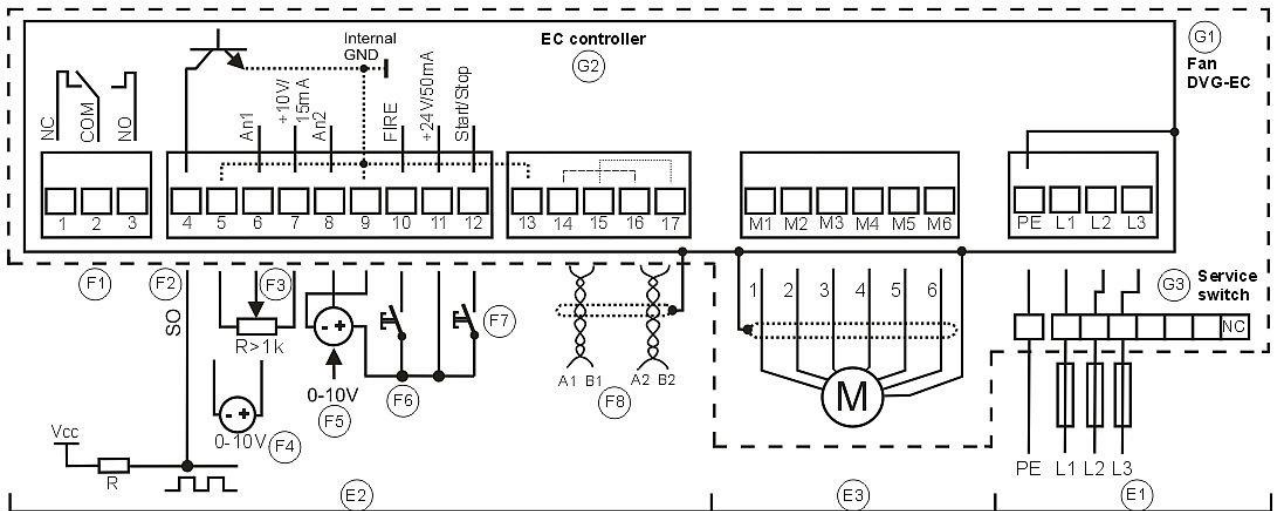

DVG 560-EC, DVG 630-EC, DVG 800-EC – Wiring 3~, 400V, 50/60Hz.....27.11.2013

Terminals 1 to 17 (lower markings in the connection box) are led from controller out to outer connection box.

3 bridges are factory inserted to allow test of fan without connecting control cables.

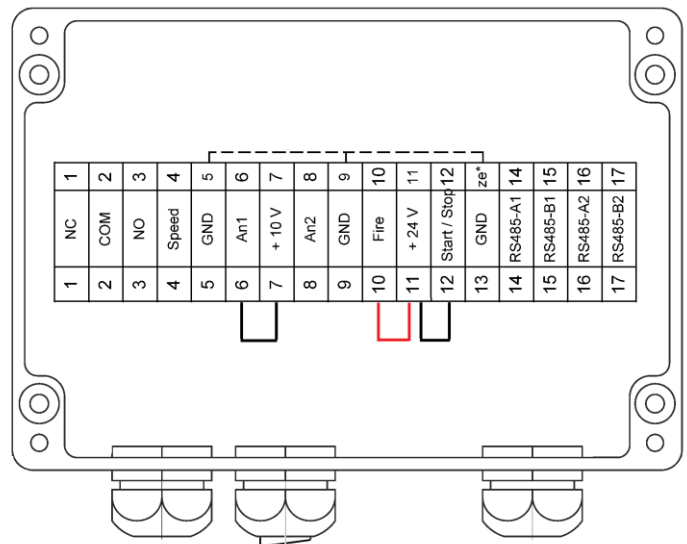

In case of using the fan for smoke and heat extraction, remove the red bridge 10-11 (fire mode) and connect controller to fire central up to wiring scheme). **Warning:** removing this bridge without connecting to fire central and running the fan in fire mode causes no protection is active. Running in fire mode is allowed only in case of fire or during periodical tests.

For fan speed setting with potentiometer remove bridge 6-7 and connect potentiometer ($R \geq 1k\Omega$) according to wiring scheme.

For fan speed setting using AN1 input (0-10V): remove bridge 6-7 and connect 0-10V input according to wiring scheme. Replace bridge 11-12 with start – stop switch.

Controller default setup controls the fan speed with potentiometer or AN1 input.

Using internal regulator for fan speed control requires change of controller setting via MODBUS (see controller instructions). Using MODBUS for fan speed control requires change of controller setting via MODBUS (see controller instructions).

Minimum fan speed can be increased in setup via MODBUS. Maximum fan speed can be decreased in setup via MODBUS.

More about settings please see controller instructions.

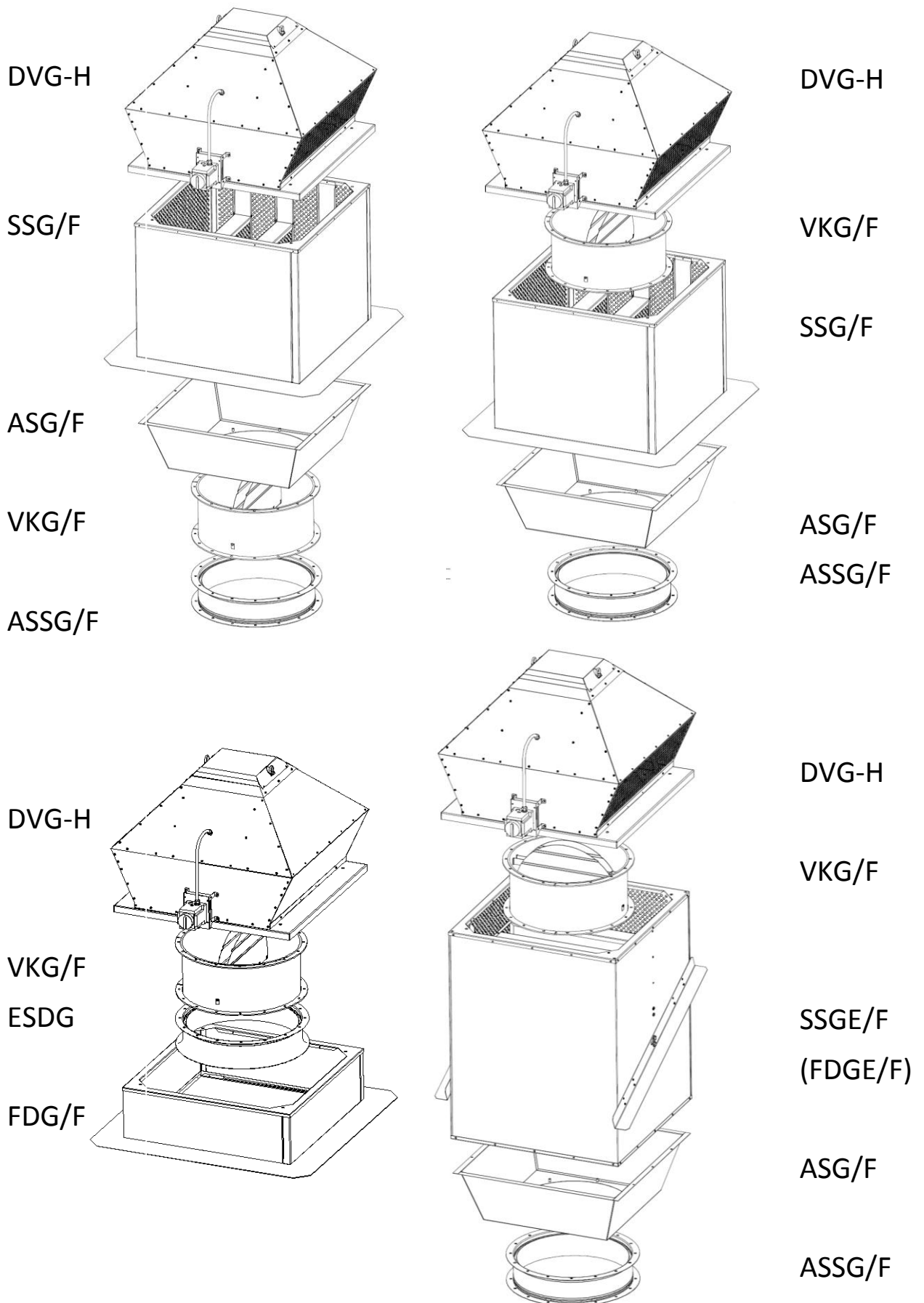

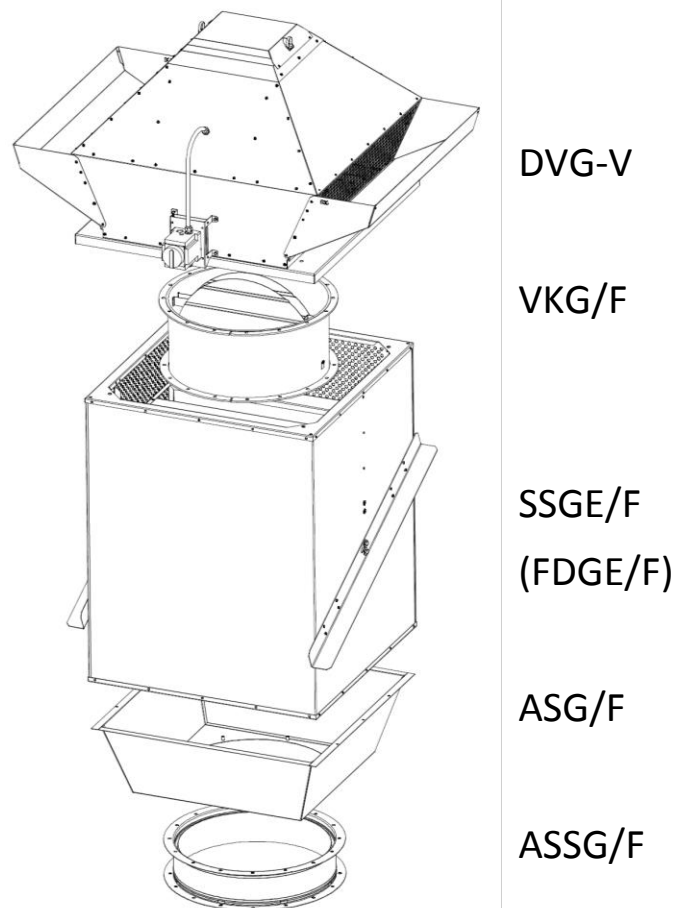
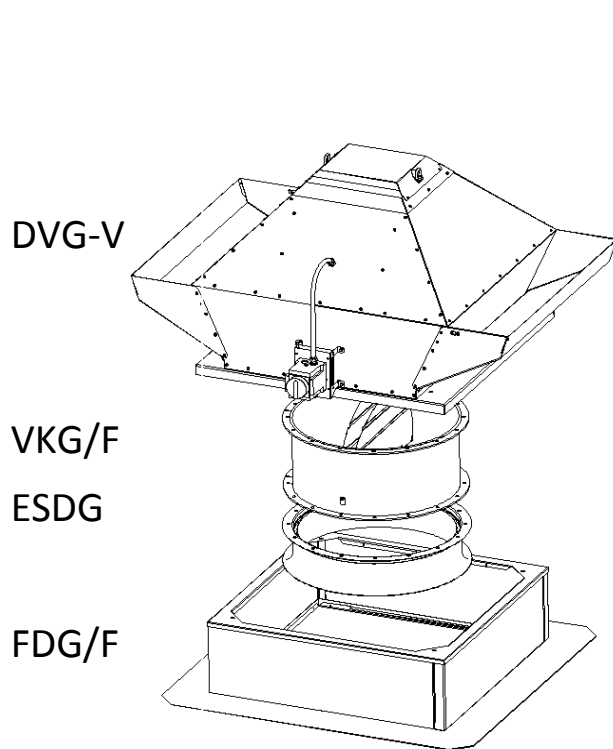
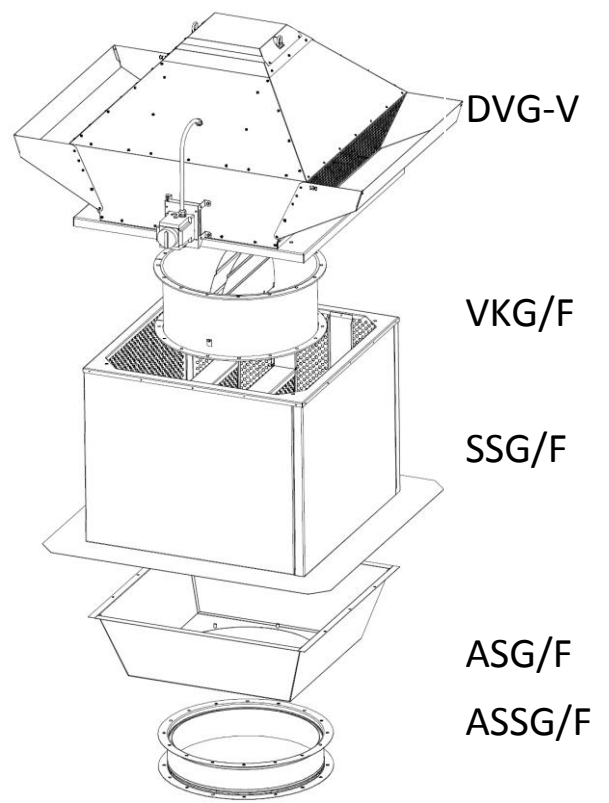
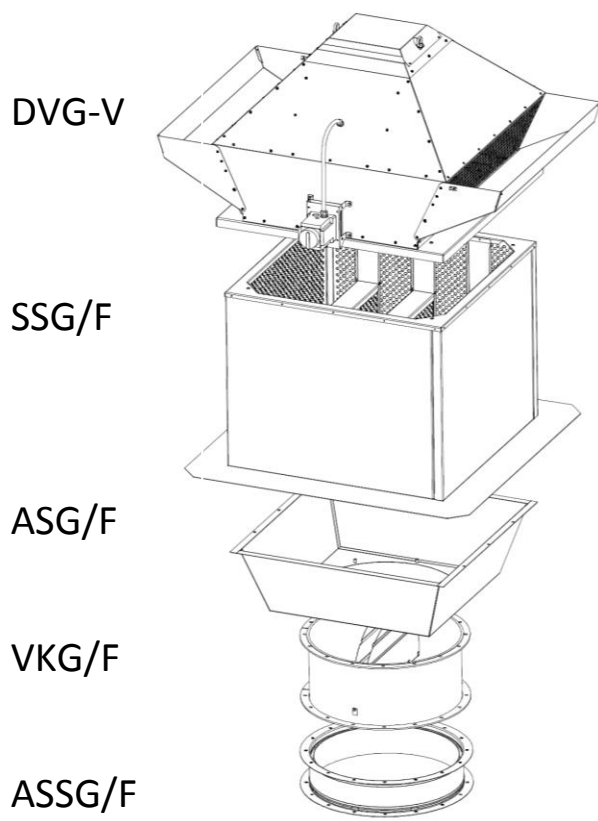



*no wire
1x blind plug D8*



*1x wire up to D5,3 mm
1x multiwire sealing insert
2x blind plug D5*



*2x wire up to D5,3 mm
1x multiwire sealing insert
1x blind plug D5*



*3x wire up to D5,3 mm
1x multiwire sealing insert
no blind plug*

All cable glands for control cables seal with multiwire sealing inserts and blind plugs to prevent moisture/dust ingress! Tighten the cable glands to obtain tightness! Attached: 2 multiwire cable inserts, 4 blind plugs D5



The Manufacturer:

Systemair d.o.o.
 Špelina 2
 SI-2000 Maribor
 Tel.: +386 2 4601 801

certifies herewith that the following products: **Smoke and heat extract fans, type DVG/F400*, DVG-EC/F400***
Thermo roof fans, type DVG-T, DVG/120

ensure all relevant regulations of following directives:

	DVG/F400	DVG-EC/F400	DVG-T	DVG/120
<i>EC Machinery Directive (2006/42/EC)</i>	x	x	x	x
<i>Electromagnetic compatibility directive (2014/30/EU)</i>	x	x	x	x
<i>Low Voltage Directive (2014/35/EC)</i>	x	x	x	x
<i>Regulation (EU) No 305/2011 (CPR)</i>	x	x	----	----
<i>Commission Regulation (EC) No 640/2009 (Ecodesign)</i>	x	----	----	x
<i>Commission Regulation (EC) No 327/2011 (Fans)</i>	x	x	----	x
<i>Regulation (EU) No 1253/2014</i>	x	x	----	x

Applied harmonized standards, in particular:

		DVG/ F400	DVG- EC/F400	DVG-T, DVG/120
EN ISO 12100	<i>Safety of machinery - General principles for design - Risk assessment and risk reduction</i>	x	x	x
EN ISO 13857	<i>Safety of machinery - Safety distances to prevent hazard zones being reached by upper and lower limbs</i>	x	x	x
EN 60204-1	<i>Safety of machinery - Electrical equipment of machines - Part 1: General requirements</i>	x	x	x
EN 12101-3	<i>Smoke and heat control systems – part 3: Specification for powered smoke and heat exhaust ventilators</i>	x	x	----

**complies with the provisions of the Test reports, issued by the LGAI Technological Center, S.A., Bellaterra (Barcelona), No. 09/100216-502 from 12. 06. 2009 and No. 11/2673-1035 from 14. 06. 2011(DVG), No. 11/3662-2628, 2629 from 09. 01. 2012 and No. 12/3662-441 from 19. 03. 2012 (DVG-EC), No. 14/3662-456 from 25. 03. 2014 (DVG, DVG-EC)*

Note1: *The compliance with EC Machinery Directive and EN ISO 13857 refers to the mounted protective guards on the inlet of the fan, as far they are in the extent of delivery. For the fully accordance with mentioned requirements (protective guards or safety assurance in other way) the performer is responsible.*

Note2: *Compliance with EMC Directive 2014/30/EC only relates to this product if it has been connected directly to the customary electricity mains. If this product is integrated into a system or completed and operated with other components (e.g. regulation and control appliances), the manufacturer or operator of the overall system is responsible for compliance with EMC Directive 2014/30/EC.*

Maribor,
 10.05.2017

Date

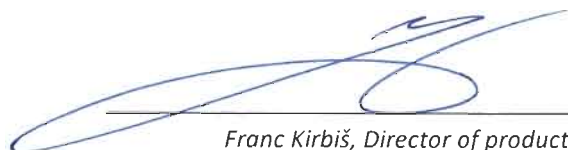

Franc Kirbiš, Director of production